

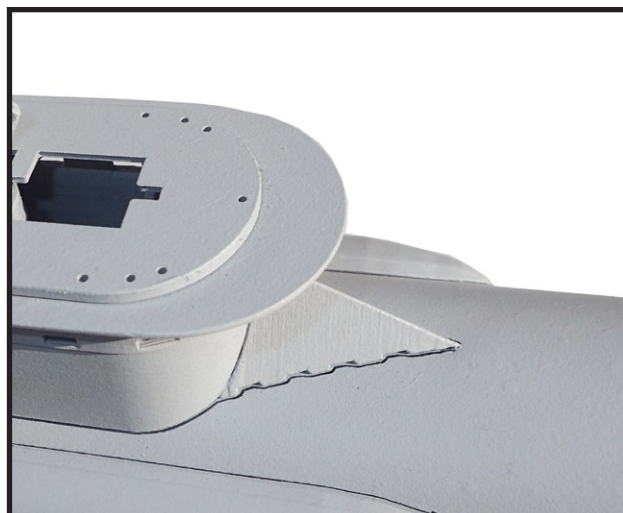

We recommend using a filler (BodyFill 360) that covers the print lines on the product. You can then sand the surface with sandpaper for a smooth surface. If the product is designed for a functional model in water, all surfaces of the product must be colored by the filler. (at least 4 layers of color). After using the bodyfill, grind the surface and stick etched parts.

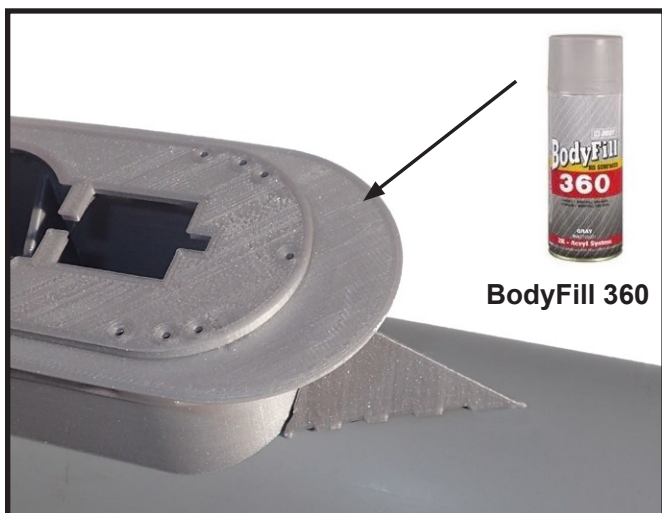

You can create welds using wire (copper / brass) diameter 1-1.2 mm

small etched parts stick super glue

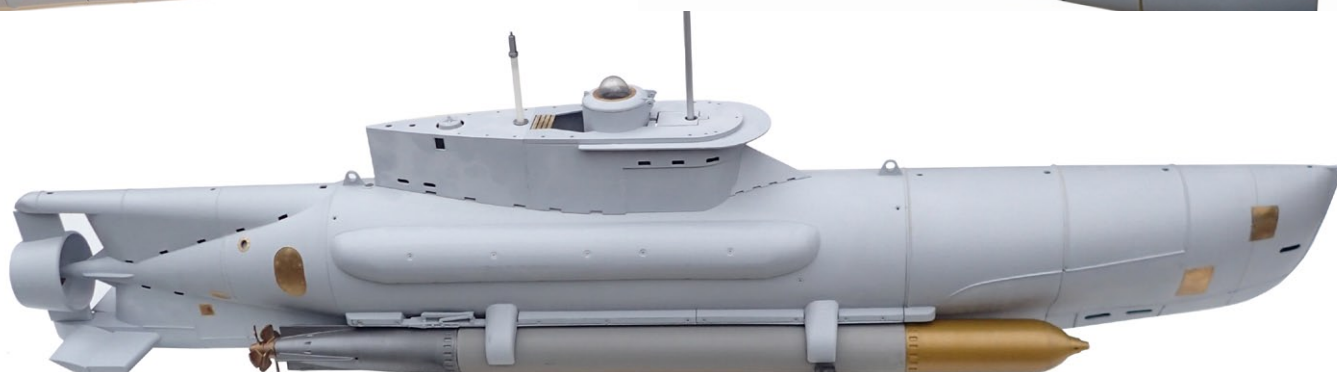
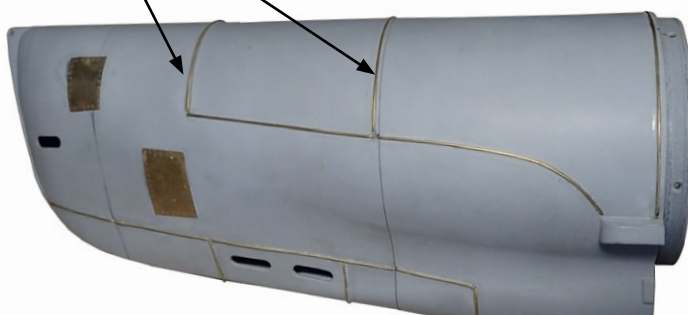

Do not expose to direct sunlight.

The printing material is PLA. This is the same material as the RC models of aircraft. yet it is not recommended to leave it in the sun.

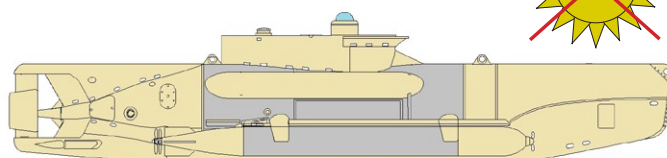
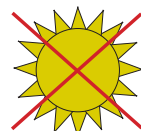

PE Description

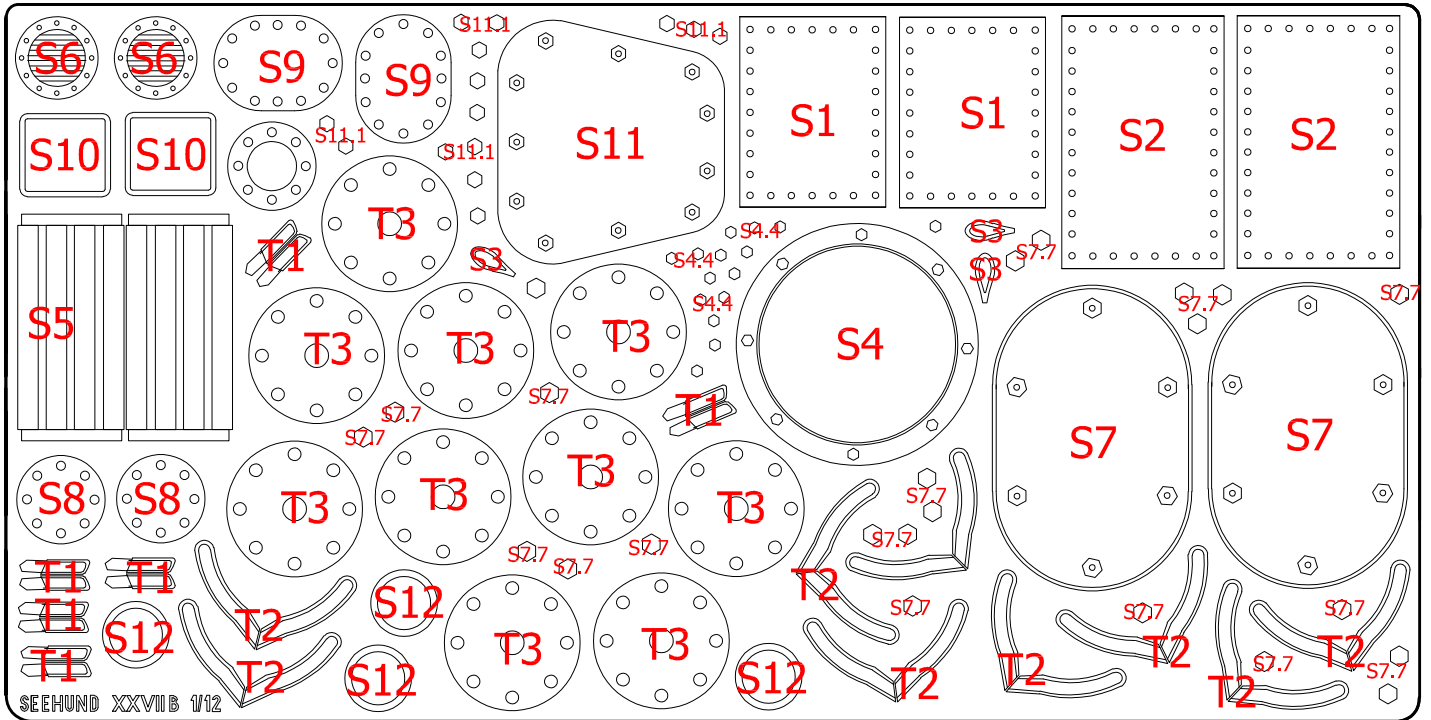

Launching lock detail

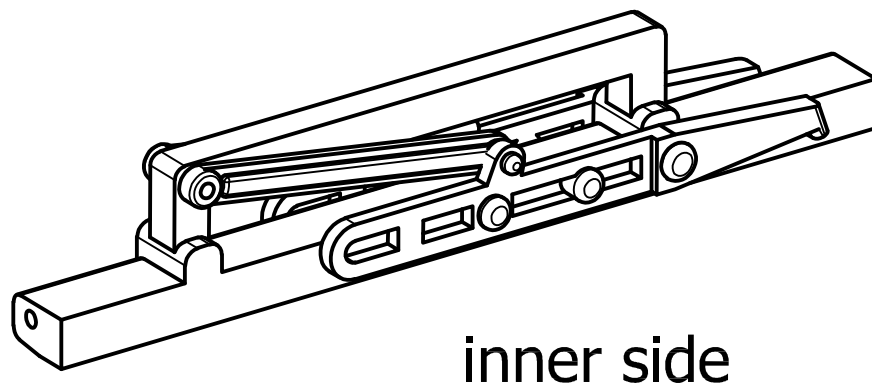
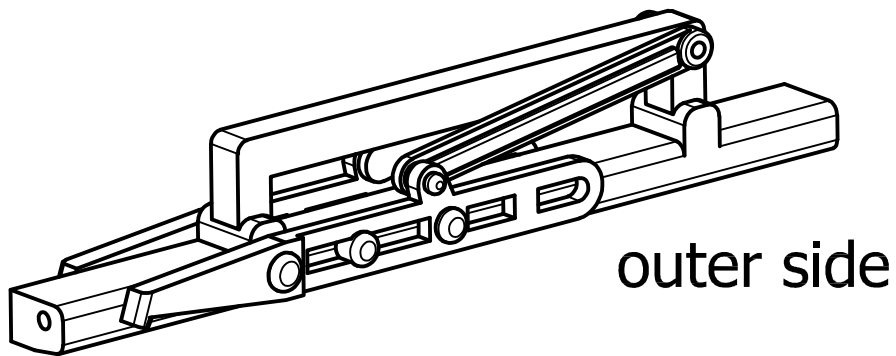

Seehund XXVIIB

scale: 1/12